

EXPERIENCE

THE HOERBIGER ADVANCED CLASS



CT valve

Reliable performance for high-speed compressors

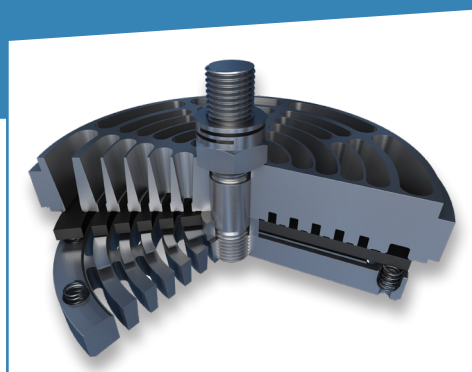

**YOUR
PROVEN
SOLUTION**

HOERBIGER
because performance counts

EXPERIENCE

THE HOERBIGER ADVANCED CLASS

Production processes are networks. Success requires that people and machines work together in unison.

Anyone who is integrated into the day-to-day production process interacts with technology, knows the pulse of the machines, their language, as well as their requirements and needs. Products made by HOERBIGER are more than state-of-the-art. As a HOERBIGER customer, you have the technological edge that allows you to always stay several steps ahead of the market. Efficiency, precision and durability are a part of HOERBIGER products, just as reliability and flexibility are hallmarks of HOERBIGER services. HOERBIGER Experience is the ideal approach when it comes to a reliable, long-lasting partnership on an equal footing.



Reliable performance for over 25 years

The HOERBIGER CT valve is suitable for virtually all applications that employ short-stroke, high-speed gas compressors. Millions of CT valves are operating successfully in the natural gas processing industry. Its plate type valve design is optimised to

utilize the properties of non-metallic valve plates and has proven its performance for years. The single moving sealing element of the CT valve allows easy maintenance (field repairable).

This is how the CT valve works

- The plastic valve plate, in conjunction with a wafer spring, dampens the opening impact.
- At high rotational speeds, the wafer spring prevents oil sticktion of the valve plate.
- Closing springs on the outside guarantee largely wobble-free valve plate movement and consequently long valve service life.

Why HOERBIGER CT valve?

- The CT valve proves operational excellence even in heavy duty upstream natural gas applications.
- Plate design and spring arrangement result in unique and smooth valve motion even in high-speed, lubricated service.
- Properly selected valve materials ensure safe operation even in sour environment.

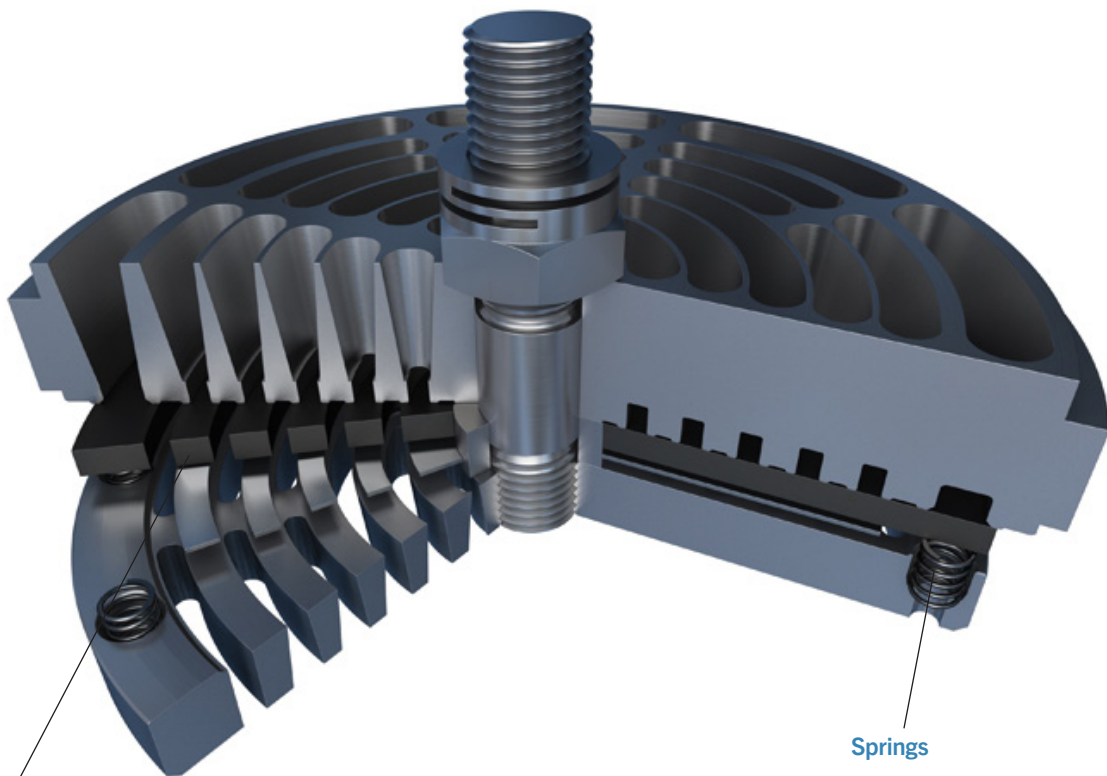

Non-metallic valve plate

made out of HOERBIGER MT-grade or PEEK material. Valve plate and wafer spring dampen the opening impact and prevent oil sticktion.

Springs

Unique peripheral spring arrangement prevents valve plate tumbling and dampens impact - this significantly contributes to the CT valve reliability and durability.

**YOUR
PROVEN
SOLUTION**

The advantages of the CT valve at a glance:

- Excellent flow efficiency for low power consumption
- Long life even in difficult and contaminated conditions
- Best suited for changing operating conditions
- Proven in lubricated and non-lubricated operation
- Resistant to gas impurities and oil sticktion
- High operating temperatures

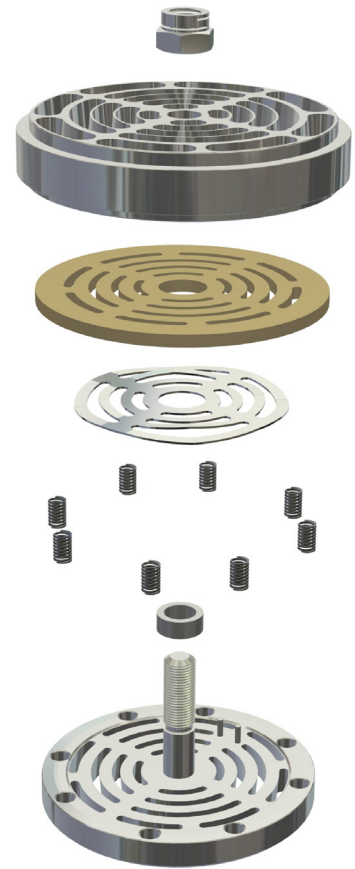

The CT valve has been developed to minimize oil sticktion while providing maximum efficiency

More than 1.000.000 CT valves are operating successfully in natural gas and process industry.

Tehnical data of the CT valve

Compressor speed:	1800 rpm maximum
Capacity control:	On/Off, HydroCOM
Lubrication:	Lube and non-lube
Maximum pressure:	350 bar
Pressure differential:	150 bar
Max. operating temperature:	230°C
Valve type diameter:	77 mm – 221 mm

www.hoerbiger.com

HOERBIGER is active throughout the world in the oil, gas, and process industries, in the automotive industry, and in safety solutions. In 2018, its 7,000 employees achieved sales of 1.222 billion euros in 110 locations and 48 countries. Our products and services are used in reciprocating compressors, gas flow control units, vehicle transmissions, gas-powered engines, automobile hydraulics, and comprehensive explosion protection solutions. It is our shared ambition to deliver excellence for our customers. As a result, we create an environment which allows our employees to develop their full potential and demonstrate initiative: people and success go hand in hand at HOERBIGER.

© HOERBIGER 2020

HOERBIGER
because performance counts